

RANCAN
Hi-Tech Laminated Densified Wood

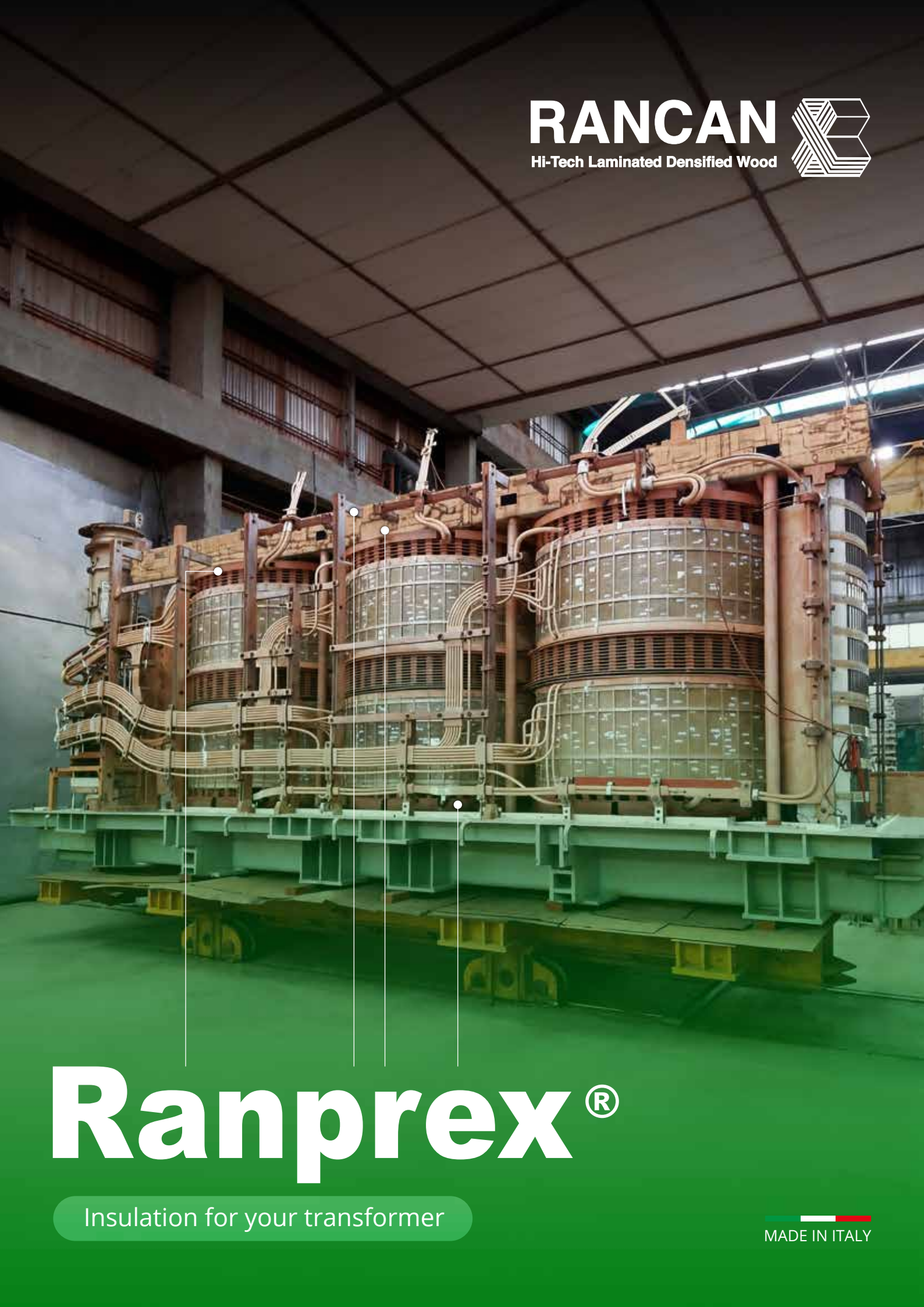

Ranprex®

Insulation for your transformer

MADE IN ITALY

RANCAN

Hi-Tech Laminated Densified Wood



Ranprex®



Ranprex®
ML20E - C2R
KP20222



Ranprex®
ML15E - C4R
KP20224



Ranprex®
ML10 - PFWV202
KP20228

Ranprex® is made of red beech veneers (*Fagus Sylvatica*) impregnated with thermosetting phenolic resin, consolidated under high pressure and temperature to obtain a high density composite according to standards IEC 61061 - DIN 7707.

Compared with other types of wood, beech wood more specifically stands out for the straight and regular structure of its fibers, which allow easy humidity release during drying process enabling, as a consequence, a very high level of oil impregnation.

Moreover, the structure of beech veneers ensures a high predictability of the mechanical resistance of the finished product, allowing to target a well-defined mechanical performance according to the chosen fiber construction and arrangement.

No other wooden essence in nature can grant similar characteristics. All the veneers we use, come from forests that are sustainably managed and PEFC certified.



Company

Insulation for your transformer

Rancan Srl: excellence in Laminated Densified Wood

Since its foundation in 1960, **Rancan Srl** has stood at the forefront of industrial innovation as a premier manufacturer of high-tech laminated densified wood. With a rich heritage spanning over 65 years, the company has masterfully refined its production processes to achieve the industry's highest quality standards. The result is **Ranprex®**, an extraordinary laminated densified red beech wood Worldwide known for its unparalleled physical, mechanical, and insulating properties. This commitment to excellence has earned Rancan Srl

a global reputation, making the company a trusted partner for the most demanding insulation and mechanical applications.

Our operations are powered by an expansive 26,000 m² facility in Montecchio Maggiore - featuring 18,000 m² of specialized covered space - which seamlessly integrates our headquarters, a secondary production unit, and advanced warehousing. This strategic infrastructure ensures that we provide our global clientele with exceptional productivity, logistical precision, and the flexibility required to meet the demands of a dynamic modern market.

Certifications

Rancan Srl is ISO 9001:2015 certified since 1999, ISO 45001:2015 since 2012, and ISO 14001:2015 since 2015, always keeping as its first targets quality, service to the customer, and competitiveness on the Global scale market.



ISO 9001:2015

QUALITY
Management
System Certificate



ISO 14001:2015

ENVIRONMENTAL
Management
System Certificate



ISO 45001:2018

**OCCUPATIONAL
HEALTH AND SAFETY**
Management
System Certificate



Plant 1

Plant 2



Material description

Fiber Arrangement

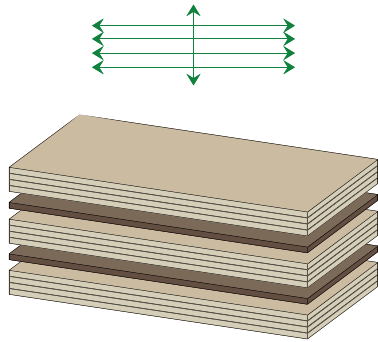

Parallel "L"

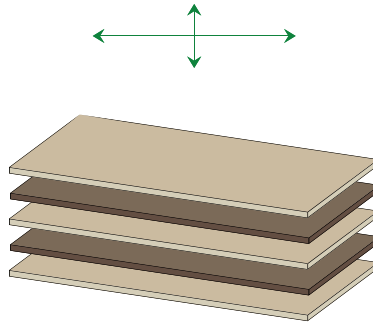

Crosswise

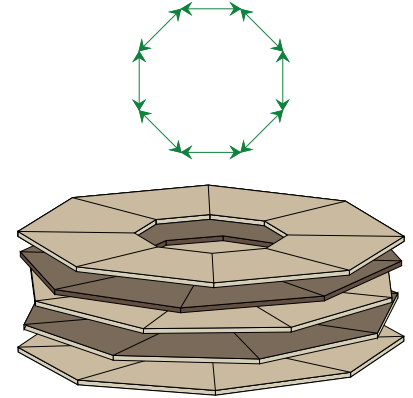

Tangential "T"

	KEY	EXPLANATION	
Material	ML	Red Beech	
Density	10	High density	1.3 ÷ 1.4
	15	Medium density	1.2 ÷ 1.3
	20	Low density	0.9 ÷ 1.1
	22	Very low density	0.7 ÷ 0.9
Use	E	Electrical application	
Lamination	NO LETTER	Crosswise	
	L	Parallel	
	T	Tangential	
Veneer quality	NO LETTER	Values according to IEC61061	
	F	First	Values higher than IEC61061
	O	Over	Values much higher than IEC61061



Crosswise / Parallel "L"



Tangential "T"



ML20E
C2R
KP20222

ML20EL
P2R
KP20212

ML15E
C4R
KP20224

ML15EL
P4R
KP20214

Technical Data

Ranprex®: High-Performance Transformer Insulation

CORE TECHNICAL ADVANTAGES

- **Superior Dielectric Performance:** Precision-selected veneers (IEC compliant) ensure excellent resistance in dielectric performance, impulse and partial discharge (PD).
- **Premium Grades:** Available in “**First**” and “**Over**” qualities, specifically engineered to minimize PD in high-voltage oil-immersed transformers.
- **High-Voltage Capability:** Field-proven in applications exceeding 800 kV.
- **Universal Oil Compatibility:** Fully compatible with mineral, silicone, and organic ester oils, maintaining chemical stability and oil integrity over the long term.

QUALITY ASSURANCE & INNOVATION

Rancan Srl maintains rigorous quality control through an internal laboratory performing physical, mechanical, and electrical testing according to IEC 61061.

By collaborating with specialized external laboratories and leading Italian universities, we ensure continuous R&D and monitoring to keep Ranprex® at the forefront of insulation technology.

Ranprex®

combines optimized fiber arrangement with material density to provide versatile electrical and mechanical solutions tailored for advanced transformer design.



TECHNICAL DATA RANPREX®	Designation	Rancan	ML22EL	ML20EL	ML15EL	ML10L	ML22E	ML20E	ML15E	ML10	ML20ET	ML15ET
		IEC 61061	P1R	P2R	P4R	PFWV304	C1R	C2R	C4R	PFWV202	T2R	T4R
		DIN 7707	KP20210	KP20212	KP20214	KP20218	KP20220	KP20222	KP20224	KP20228	KP20242	KP20244
	Standard	Unit	Parallel 				Crosswise 				Tangential 	

Physical properties

DENSITY	IEC61061	g/cm ³	0.7 ÷ 0.9	0.9 ÷ 1.1	1.2 ÷ 1.3	1.3 ÷ 1.4	0.7 ÷ 0.9	0.9 ÷ 1.1	1.2 ÷ 1.3	1.3 ÷ 1.4	0.9 ÷ 1.1	1.2 ÷ 1.3
OIL ABSORPTION	IEC61061	%	32	30	7	/	30	28	10	/	28	7.5
CONTINUOUS WORKING TEMPERATURE	-	°C	105	105	105	100	105	105	105	100	105	105
TEMPERATURE LIMIT FOR DRYING PROCESS	-	°C	140	140	140	130	140	140	140	130	140	140
CONTAMINATION OF DIELECTRIC LIQUIDS	IEC61061	Δtg δ	< 0.1	< 0.1	< 0.1	< 0.1	< 0.1	< 0.1	< 0.1	< 0.1	< 0.1	< 0.1

Mechanical properties

FLEXURAL STRENGTH 1)	IEC61061 UNI EN ISO 178	MPa	145	150	200	220	120	130	140	150	135	180
MODULUS OF ELASTICITY IN FLEXURE	IEC61061 UNI EN ISO 178	GPa	10	14	16	18	7.5	9.5	12	15	11	13
COMPRESSIVE STRENGTH	IEC61061 UNI EN ISO 604	MPa	130	130	145	170	150	210	245	240	140	160
			95	95	130	160	60	75	110	170	/	/

Electrical properties

ELECTRIC STRENGTH	IEC 61061 IEC 60243	kV/ mm	/	15	16	18	7	15	16	18	7	16	18
			F	16	17	19	8	16	17	19	8	17	19
			O	17	18	20	9	17	18	20	9	18	20
BREAKDOWN VOLTAGE	IEC 61061 IEC 60243	kV/ 25mm	> 80	> 80	> 80	> 25	> 80	> 80	> 80	> 25	> 80	> 80	
SURFACE RESISTIVITY	IEC 60093	Ω	10 ¹²	10 ¹²	10 ¹²	10 ¹¹	10 ¹²	10 ¹²	10 ¹²	10 ¹¹	10 ¹²	10 ¹²	
VOLUME RESISTANCE	IEC 60093	Ω cm	10 ¹²	10 ¹²	10 ¹²	10 ¹¹	10 ¹²	10 ¹²	10 ¹²	10 ¹¹	10 ¹²	10 ¹²	
DISSIPATION FACTOR	IEC 60250	tg δ	0.01	0.01	0.01	0.01	0.01	0.01	0.01	0.01	0.01	0.01	
RELATIVE PERMITTIVITY	IEC 60250	ε _r	3.3	3.5	3.8	4.2	3.3	3.5	3.8	4.2	3.5	3.8	

Transformer insulations parts

Ranprex®



RANPREX® FOR **CORE INSULATION**

For a proper core insulation, support and stability Ranprex is widely used to manufacture:

Core Clamping Beams

Step Blocks

Blocks



RANPREX® FOR **WINDING INSULATION**

For an effective performance of the active part, Ranprex is widely use in the production of:

Pressure Rings and Plates

Cable Fixing Ledges

Blocks

Bottom Support Rings and Plates

Shield and End Rings



RANPREX® FOR **ACCESSORIES**

As a completion of transformer insulations, we propose Ranprex as:

Threaded Rods

Nuts

Round Rods

Which parts can be machined out of Ranprex®? _____.



Sustainable Innovation

Ranprex® Coil Clamping Beams

Optimizing Transformer Performance Through Advanced Material Science

In alignment with global energy directives (such as [2009/125/EC](#)), Rancan Srl is leading the transition from traditional steel to **Ranprex® laminated densified wood** for transformers coils clamps.

By replacing metal with our PEFC-certified, 100% natural insulating material, manufacturers can achieve superior efficiency and a reduced carbon footprint.



Our research on distribution and medium-power transformers confirms **four critical advantages:**

01. Significant Loss Reduction

Eliminating metallic beams removes the primary source of stray losses outside the winding:

- **Efficiency:** Reduces load losses by **4% to 8%**
- **Clean Energy:** Ideal for transformers with high-harmonic environments like photovoltaic plants.
- **Cost Savings for improved competitiveness:** transformer does not waste the energy it creates.

03. Compact Design & Material Savings

Ranprex® acts as both a structural and insulating component, allowing for tighter clearances between active parts.

- **Miniaturization:** Smaller internal distances result in a more compact transformer and a smaller tank.
- **Resource Efficiency:** Significant reduction in the volume of insulating oil, copper, and steel required.
- **Cost saving:** reduced amount of valuable components, reflecting on a better cost saving on transformer selling cost.

02. Optimized Operating Temperatures

The non-metallic nature of Ranprex® eliminates the risk of “hot spots.”

- **Thermal Stability:** Prevents oil gasification by keeping temperatures below critical thresholds.
- **Longevity:** Preserves the dielectric properties of the oil and prevents premature insulation aging.
- **Safety:** Dramatically reduces the risk of discharges and internal short circuits.

04. Superior Partial Discharge (PD) Control

In high-stress electric fields, metal clamps increase the risk of PD inception.

Ranprex® provides a safer, high-insulation alternative.

- **Precision Finishing:** Expertly machined with smooth, rounded edges to eliminate electric field concentrations.
- **Simplified Engineering:** Eases grounding requirements and potential control.
- **Reliability:** complying to IEC norms for PD levels, ensuring long-term operational security and an overall improved performance of the transformer.

Shield & End Rings

Ranprex®

Ranprex®, being **easily machinable** and having a **great resistance to flexion**, is suitable to produce **supports for shield and end rings**.

It is important to stress that in such a critical and delicate component the mechanical features of the material used as a support become fundamental. Also in this case, thanks to the **resistance and arrangement of the wooden fibers**, our Ranprex® grants **excellent mechanical performance**, contrarily to other materials which cannot exploit the same type of structure.

Rancan Srl, being aware of their customers' needs, can provide these **components already machined, fully insulated** according to drawing, and **ready to be installed** in the transformer.



Shield rings



End rings



Detail of shield ring



End rings for power transformers



Fully insulated shield rings



Fully insulated end rings

Ranprex[®]

RANCAN
Hi-Tech Laminated Densified Wood





RANCAN

Hi-Tech Laminated Densified Wood

A stylized graphic logo consisting of several parallel lines that form a three-dimensional, geometric shape resembling a cube or a stack of wood layers, with a central 'X' or 'E' shape.

RANCAN SRL

HEADQUARTERS - PLANT 1

Via della Tecnica, 9 (Z.I.)
36075 Montecchio Maggiore (VI) Italy

E-mail: rancan@rancan.com

Telefono: +39 0444.499234

Fax: +39 0444.499311

PLANT 2

Via 1° Maggio, 9 (Z.I.)
36075 Montecchio Maggiore (VI) Italy

www.rancan.com

