

4610 Series

Part#	Part Height	Thread Size and Depth	Thd Depth in dec	Insert Length	# of Inserts
GINS-4610-15	3.5"	3/8-16x11/16 deep	.669"	.787"	2 top 4 bottom
GINS-4610-81	3.5"	3/8-16x11/16 deep	.669"	.787"	4 top 4 bottom
GINS-4610-M15	88.9 mm	M10-1.5 x 17 deep		20 mm	2 top 4 bottom
GINS-4610-M81	88.9 mm	M10-1.5 x 17 deep		20 mm	4 top 4 bottom

TABLE

Linear	Inj. moulding	Comp. Moulding	Metal
.236" to 1.181"	±.019"	±.019"	±.008"
1.181" to 4.724"	±.031"	±.039"	±.011"
4.724" to 15.748"	±.047"	±.059"	±.019"
15.748" to 39.37"	±.078"	±.098"	±.031"

Inserts

Part#	Material
As shown	Aluminum
Followed by -B	Brass
Followed by -S	Steel

Hex shaped Inserts

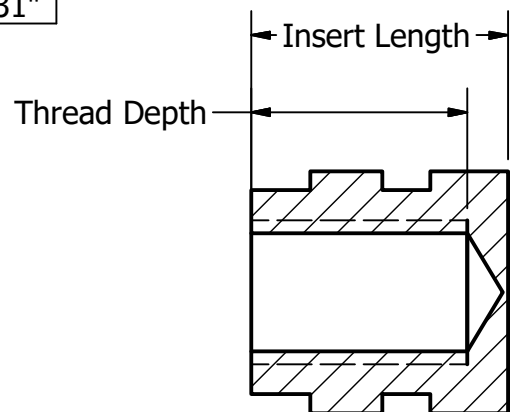

VIEW B-B

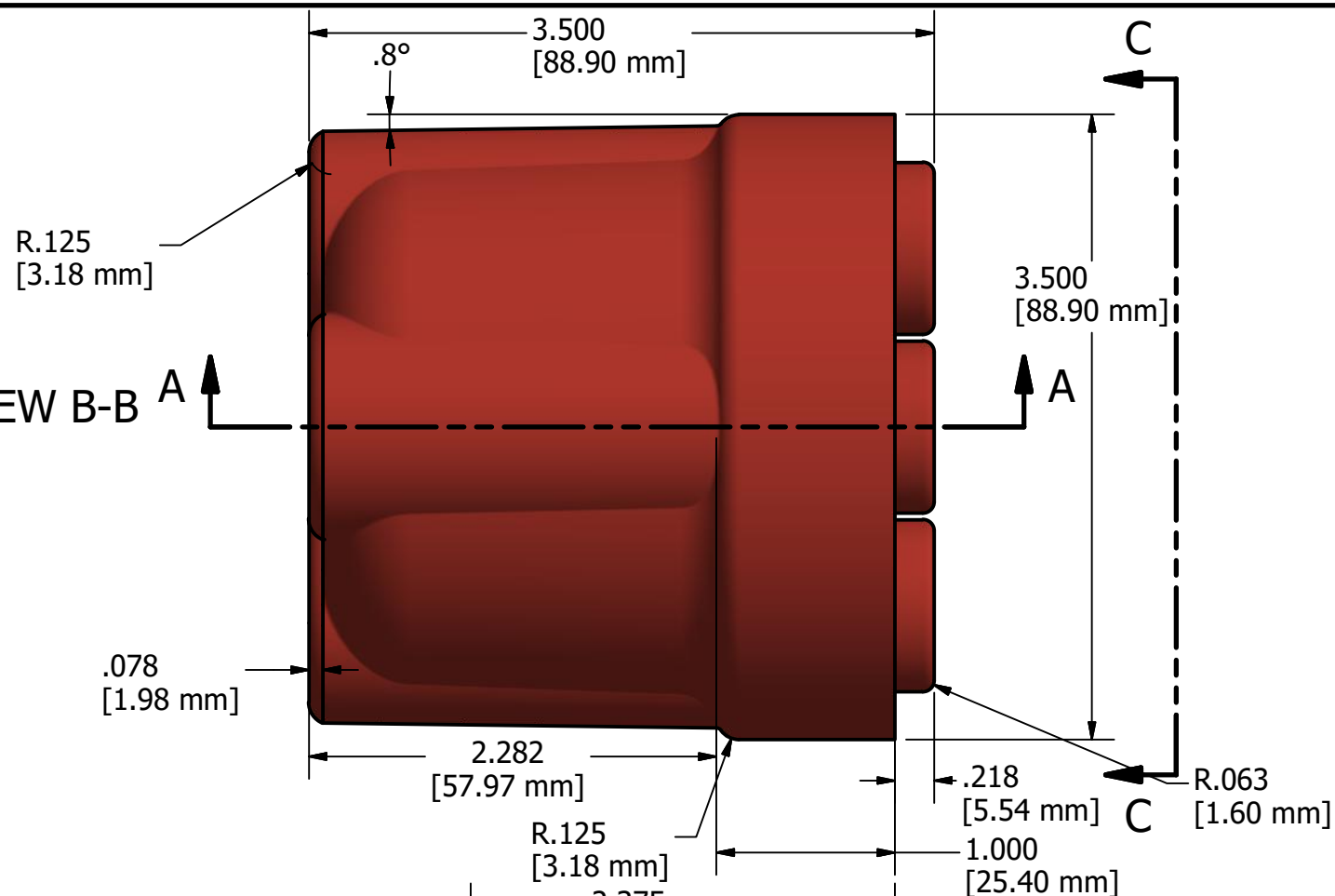

SECTION A-A  
SCALE 1 : 1

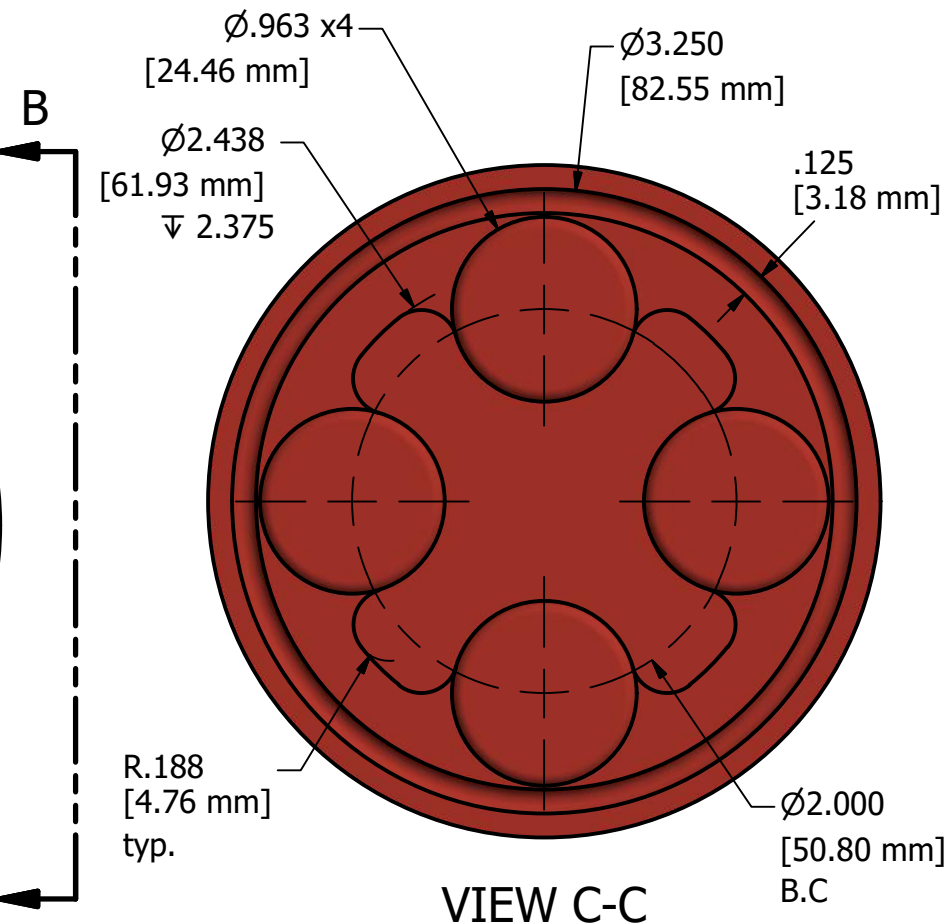
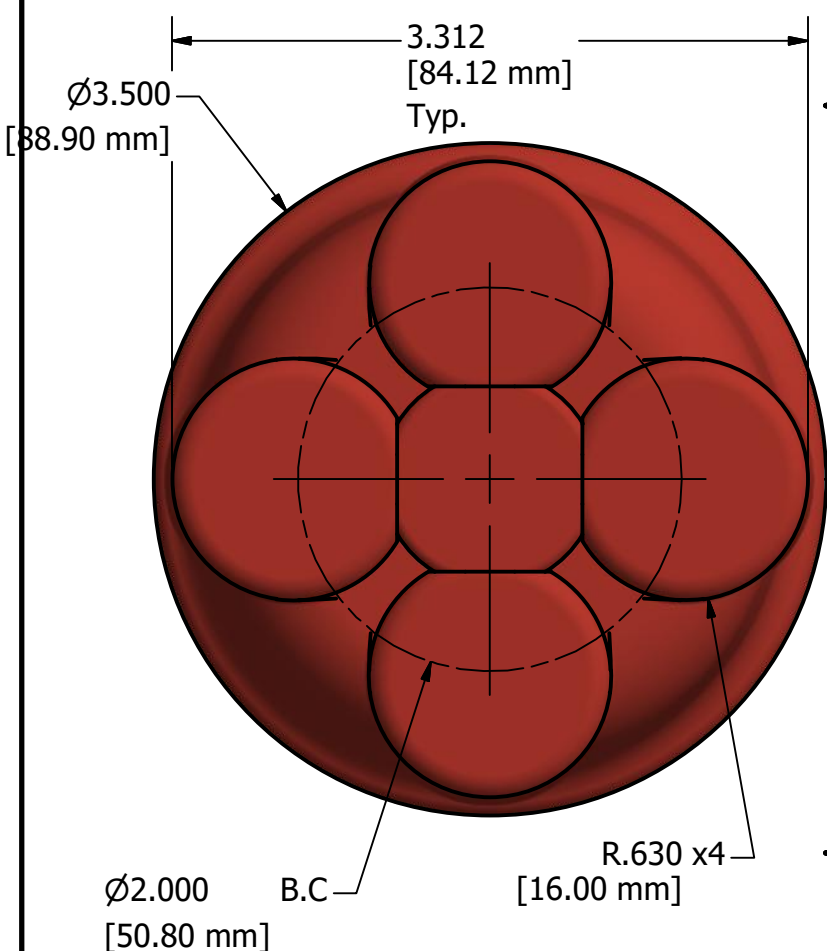
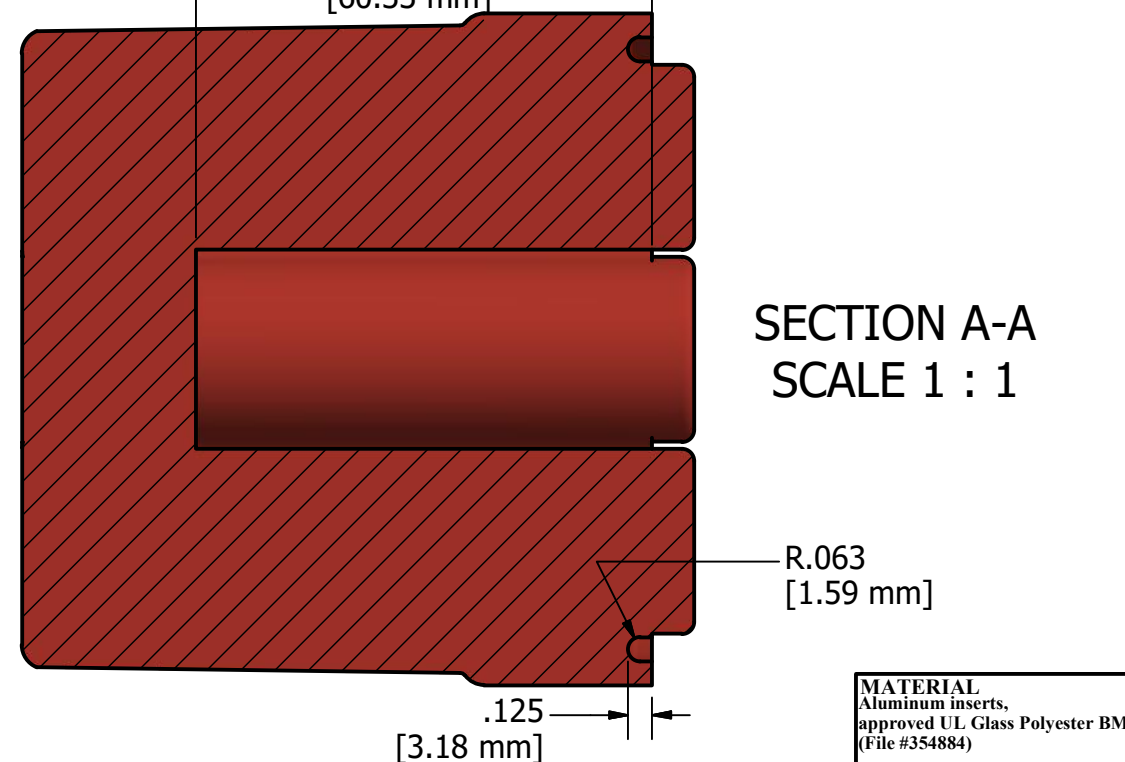

CONFIDENTIAL AND PROPRIETARY FOR THE GUND COMPANY USE ONLY

Notes:

APPROVED BY  
*Solomon Chiang*

DRAWN BY  
Corey Smith

DRAWING DATE  
3/3/15 Rev 0

PART NAME  
GINS-4610 Stand Off Series

CUSTOMER CONTACT

FACILITY

MATERIAL  
Aluminum inserts,  
approved UL Glass Polyester BMC  
(File #354884)

QTY

TOLERANCES

.xx ±  
.xxx ±  
Fract: ±  
Angle: ±  
Other: ±

Drawing Reference



2121 WALTON ROAD  
ST LOUIS MO 63114 USA  
(314)-423-5200  
FAX (314)-423-9009